

MIH4.2ESDX 50Hz ***Indirect Fired Heater*** ***Owner's Manual***

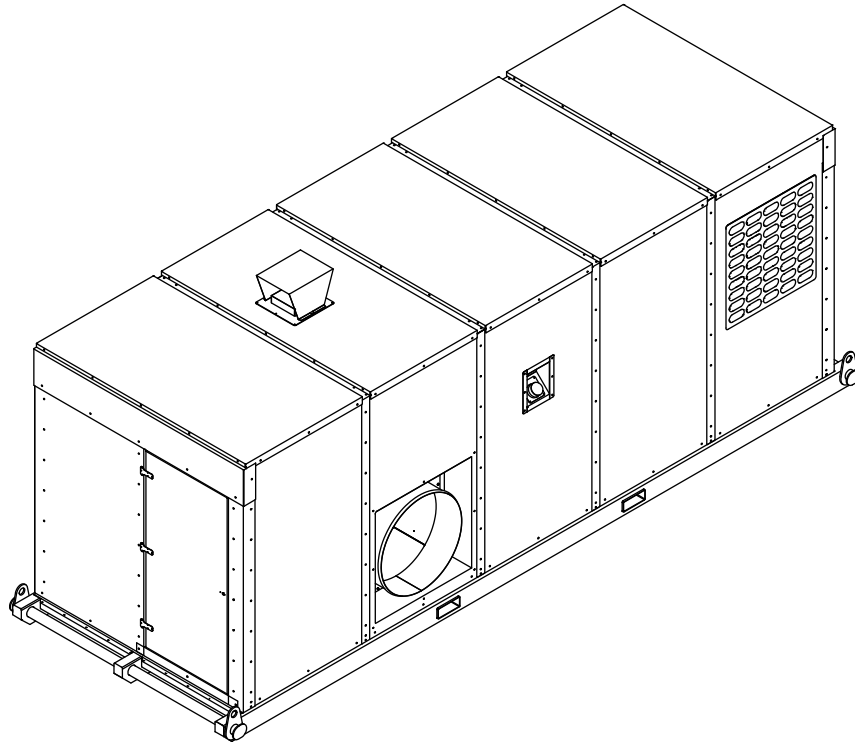

MODEL NUMBER: _____

SERIAL NUMBER: _____

DATE PURCHASED: _____

SAVE THIS MANUAL FOR FUTURE REFERENCE

⚠ WARNING

California Proposition 65. Engine exhaust and some of its constituents are known to the state of California to cause cancer, birth defects, and other reproductive harm. (000004)

⚠ WARNING

California Proposition 65. This product contains or emits chemicals known to the state of California to cause cancer, birth defects, and other reproductive harm. (000005)

Table of Contents

Section 1: Introduction and Safety

Introduction	1
Read This Manual Thoroughly	1
Safety Rules	1
How to Obtain Service	1
General Hazards	2
Explosion and Fire Hazards	2
Electrical Hazards	2
Safety and Operating Decals	3

Section 2: General Information

Specifications	5
Component Locations	6
Control Panel	7
Fuel System	8
Electrical Connection	8

Section 3: Operation

Theory of Operation	9
Placement	9
Before Starting	9
Pre-Start Checklist	9
Ducting Guidelines	9
Heater Startup	9
General Overview	10
Operational Procedure	10
Adjusting Heater Output	10
Thermostat	10
Thermostat Control	10
Heater Shutdown	11
Emergency Shutdown	11

Section 4: Maintenance

Maintenance	13
Maintenance Tasks	13
Daily Walk Around Inspection	13
Maintenance Schedule	13
Maintenance Schedule	14
Other Maintenance Checks	14

Section 5: Troubleshooting

General Troubleshooting Guide	15
--	----

Section 6: Installation Diagrams

Blower Panel (1 of 2)	17
Wiring Diagram	19

This page intentionally left blank.

Section 1: Introduction and Safety

Introduction

Thank you for purchasing a Generac Mobile Products, LLC product. This unit has been designed to provide high-performance, efficient operation, and years of quality use when maintained properly.

The MIH4.2ESDX 50Hz indirect air heater is designed and built for sustained, reliable heat production in industrial operating conditions and environments. The MIH4.2ESDX 50Hz is built to withstand frequent handling under these conditions. The fully enclosed design protects the operating components, allowing all-weather storage and operation.

The information in this manual is accurate based on products produced at the time of publication. The manufacturer reserves the right to make technical updates, corrections, and product revisions at any time without notice.

Read This Manual Thoroughly



Consult Manual. Read and understand manual completely before using product. Failure to completely understand manual and product could result in death or serious injury. (000100a)

If any section of the manual is not understood, contact your nearest Generac Mobile Products (GMP) Authorized Service Dealer (ASD), or contact Generac Mobile Products Customer Service at 800-926-9768, or visit <http://www.generacmobileproducts.com> with any questions or concerns.

The owner is responsible for proper maintenance and safe use of the equipment.

SAVE THESE INSTRUCTIONS for future reference. This manual contains important instructions for the unit that should be followed during installation, operation, and maintenance of the unit. ALWAYS supply this manual to any individual that will use this unit.

Safety Rules

The manufacturer cannot anticipate every possible circumstance that might involve a hazard. The alerts in this manual, and on tags and decals affixed to the unit, are not all inclusive. If using a procedure, work method, or operating technique that the manufacturer does not specifically recommend, verify that it is safe for others and does not render the equipment unsafe.

Throughout this publication, and on tags and decals affixed to the unit, DANGER, WARNING, CAUTION, and

NOTE blocks are used to alert personnel to special instructions about a particular operation that may be hazardous if performed incorrectly or carelessly. Observe them carefully. Alert definitions are as follows:



Indicates a hazardous situation which, if not avoided, will result in death or serious injury.

(000001)



Indicates a hazardous situation which, if not avoided, could result in death or serious injury.

(000002)



Indicates a hazardous situation which, if not avoided, could result in minor or moderate injury.

(000003)

NOTE: Notes contain additional information important to a procedure and will be found within the regular text of this manual.

These safety alerts cannot eliminate the hazards that they indicate. Common sense and strict compliance with the special instructions while performing the action or service are essential to preventing accidents.

How to Obtain Service

When the unit requires servicing or repairs, contact a GMP ASD for assistance. Service technicians are factory-trained and are capable of handling all service needs. Go to <http://www.generacmobileproducts.com/parts-service/find-service> for assistance locating a dealer.

When contacting a GMP ASD about parts or service, always supply the complete model and serial number of the unit as given on its data decal located on the unit. Record the model and serial numbers in the spaces provided on the inside front cover of this manual.

General Hazards

⚠️ WARNING

Risk of injury. Do not operate or service this machine if not fully alert. Fatigue can impair the ability to service this equipment and could result in death or serious injury. (000215)

⚠️ WARNING

Equipment damage. Do not attempt to start or operate a unit in need of repair or scheduled maintenance. Doing so could result in serious injury, death, or equipment failure or damage. (000291)



⚠️ WARNING

Hearing Loss. Hearing protection is recommended when using this machine. Failure to wear hearing protection could result in permanent hearing loss. (000107)



⚠️ WARNING

Moving Parts. Keep clothing, hair, and appendages away from moving parts. Failure to do so could result in death or serious injury. (000111)



⚠️ WARNING

Hot Surfaces. When operating machine, do not touch hot surfaces. Keep machine away from combustibles during use. Hot surfaces could result in severe burns or fire. (000108)



⚠️ WARNING

Vision loss. Eye protection is required when servicing unit. Failure to do so could result in vision loss or serious injury. (000377)

⚠️ CAUTION

Equipment or property damage. Do not block air intake or restrict proper air flow. Doing so could result in unsafe operation or damage to unit. (000229)

Explosion and Fire Hazards

⚠️ DANGER



Explosion and Fire. Fuel and vapors are extremely flammable and explosive. Add fuel in a well ventilated area. Keep fire and spark away. Failure to do so will result in death or serious injury. (000105)



⚠️ WARNING

Risk of Fire. Unit must be positioned in a manner that prevents combustible material accumulation underneath. Failure to do so could result in death or serious injury. (000147)

Electrical Hazards

⚠️ DANGER



Electrocution. In the event of electrical accident, immediately shut power OFF. Use non-conductive implements to free victim from live conductor. Apply first aid and get medical help. Failure to do so will result in death or serious injury. (000145)

⚠️ DANGER



Electrocution. Water contact with a power source, if not avoided, will result in death or serious injury. (000104)

⚠️ DANGER



Electrocution. Verify electrical system is properly grounded before applying power. Failure to do so will result in death or serious injury. (000152)

⚠️ DANGER



Electrocution. Do not use unit if electrical wiring is cut or worn through. Doing so will result in death or serious injury. (000378)

⚠️ WARNING

Only a trained and licensed electrician should perform wiring and connections to unit. Failure to follow proper installation requirements could result in death, serious injury, and damage to equipment or property. (000155)

Safety and Operating Decals

See **Figure 1-1**. This unit features numerous safety and operating decals. These decals provide important operating instructions and warn of dangers and hazards. The following diagrams illustrate decal locations and descriptions.

Replace any missing or hard-to-read decals and use care when washing or cleaning the unit. Decal part numbers can be found in the parts manual, available at <http://www.generacmobileproducts.com>.

ID	Description
A	Hot Surface Warning: Do Not Enter Intake
B	Diesel Fuel Hazards
C	Ultra Low Sulfur Fuel Only
D	Moving Parts: Do Not Remove Screen
E	Lifting Eye/Tie-Down Location: Right
F	Forklift Pocket Location
G	Lifting Eye/Tie-Down Location: Left
H	Keep Doors Closed
I	Thermostat Instructions
J	Operating Instructions

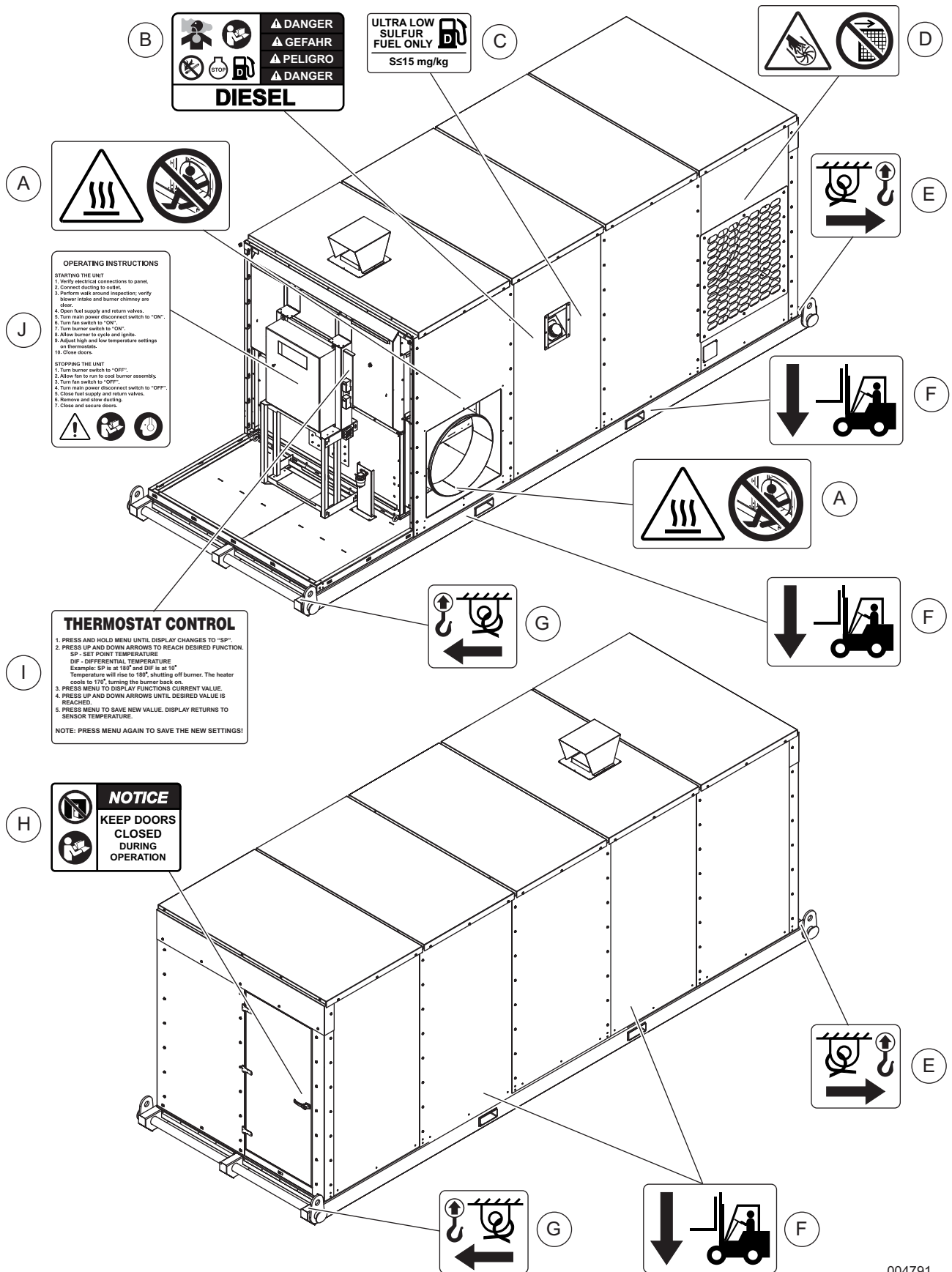

Figure 1-1. External Decals

004791

Section 2: General Information

Specifications

Heater	4,225,500 BTU/hr (1,238.4 kW/hr) maximum
Type	Indirect fired
Power	30 hp electric motor
Fan Operating Speed	1,460 rpm
Air Volume	21,000 CFM (35,679 m ³ /hour)
Static Pressure	3 in H ₂ O (0.75 kPa)
Air Outlet	36 in (91.4 cm)
Electrical	380V, 50Hz incoming line
Burner	Riello, RL 130/M
Burner Type	2 Stage/modulating
Burner Fuel	Diesel
Fuel Tank Capacity	160 gal (606 L)
Burner Fuel Rate (at 100% prime)	31.3 gph (118 Lph)
Total Maximum Run Time	5.1 hrs
Temperature Rise	180 °F (82 °C)
Fan	Class 2, SWSI, 300 BC
Duct Diameter	36 in (91.4 cm)
Maximum Duct Length	30 ft (9.1 m)
Estimated Heater Efficiency	85%
Dimensions	289 in x 102 in x 118 in (7.34 m x 2.59 m x 2.99 m)
Weight	14,260 lbs (6,468.2 kg) operating weight, skid mounted

Component Locations

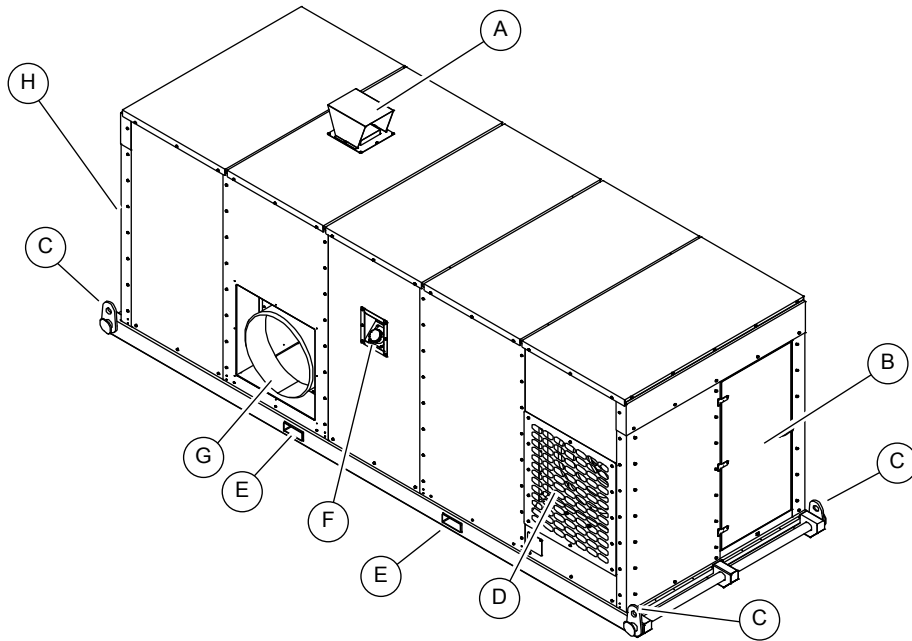

004615

Figure 2-1. External Component Locations

- | | | | |
|---|-----------------|---|--------------------------------|
| A | Exhaust stack | E | Forklift pocket |
| B | Fan access door | F | Diesel fuel fill |
| C | Lifting eye | G | Air outlet |
| D | Air inlet | H | Burner access door (not shown) |

Control Panel

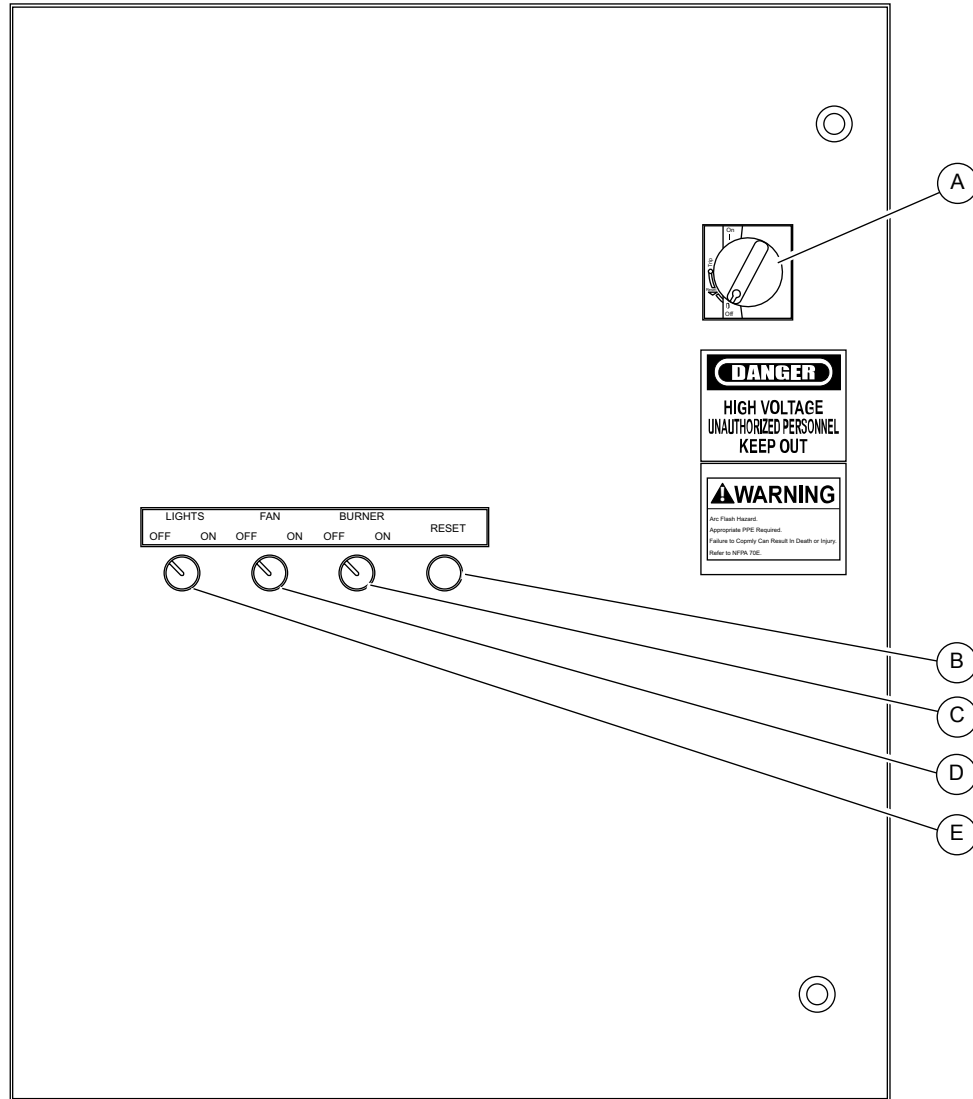

004790

Figure 2-2. Control Panel Component Locations

- | | | | |
|---|------------------------------|---|----------------------|
| A | Main power disconnect switch | D | Fan on/off switch |
| B | Reset button | E | Lights on/off switch |
| C | Burner on/off switch | | |

Fuel System



⚠ DANGER

Explosion and Fire. Fuel and vapors are extremely flammable and explosive. Keep fire and spark away. Failure to do so will result in death or serious injury. (000168)



⚠ DANGER

Explosion and Fire. Do not overfill fuel tank. Overfilling may cause fuel to leak and ignite or explode, resulting in death or serious injury. (000204)

This burner is designed to operate with diesel fuel.

NOTE: Comply with all laws regulating the storage and handling of fuels.

Follow these guidelines:

- Use ultra-low-sulfur diesel fuel only.
- When temperatures are at or below freezing, use No. 1D diesel fuel.
- When temperatures are above freezing, use No. 2D diesel fuel.
- In some areas of the country, climatized fuel—a mixture of 1D and 2D—may also be used.

Electrical Connection



⚠ DANGER

Electrocution. In the event of electrical accident, immediately shut power OFF. Use non-conductive implements to free victim from live conductor. Apply first aid and get medical help. Failure to do so will result in death or serious injury. (000145)



⚠ DANGER

Electrocution. Do not use unit if electrical wiring is cut or worn through. Doing so will result in death or serious injury. (000378)



⚠ DANGER

Electrocution. Verify electrical system is properly grounded before applying power. Failure to do so will result in death or serious injury. (000152)

⚠ WARNING

Only a trained and licensed electrician should perform wiring and connections to unit. Failure to follow proper installation requirements could result in death, serious injury, and damage to equipment or property. (000155)

IMPORTANT NOTE: The unit is powered with three line power cables routed through the incoming electrical port and connected to the distribution block inside the control panel. Incoming power must be 380V 50Hz.

IMPORTANT NOTE: Inrush amperage to start the blower is 237A at 57kW. Amperage will drop to operating levels once fan is running.

Section 3: Operation

Theory of Operation

When the thermostat is set at a temperature, the indirect heater generates heat when the burner unit is turned on. This combustion heats the blast box, and the hot air then radiates through the transition. A fan pulls cool air through the intake and pushes it over and through the heat exchanger. The heated air flows out of the discharge and through the ducting.

Placement

- Unit must be placed on firm, flat, dry ground.
- Do not place unit on an incline.
- Use the lifting eyes and proper lifting equipment to move the unit.
- Do not operate unit on a flat bed trailer or transport device.
- Place unit a minimum of 10 ft (3 m) away from structures and barricades.

Before Starting

Pre-Start Checklist



WARNING

Hot Surfaces. When operating machine, do not touch hot surfaces. Keep machine away from combustibles during use. Hot surfaces could result in severe burns or fire.

(000108)

- Remove all flammable materials and fire hazards within 10 ft (3 m) of the unit.
- Keep unit a minimum of 10 ft (3 m) from structures or barricades.
- Inspect inside and outside the unit for leaking fuel.
- Verify the following are clear of debris and obstructions:
 - Burner air intake
 - Exhaust stack
 - Outlets and fan intakes
- Verify air duct hose is securely fastened to outlet duct assembly.
- Inspect fuel supply assembly for proper installation and security.
- Verify fuel valves are open.
- Verify tank return line is clear of obstructions.
- Verify burner mounting system is secure.

- Inspect electrical wiring, components, and controls for abnormalities.
- Verify all burner and fan compartment electrical switches and disconnects are OFF.
- Verify fan motor mount security and alignment.
- Inspect fan shaft and bearing for security and proper installation.

Ducting Guidelines

WARNING

Burn hazard. Do not remove ducting until all air pressure has been emptied from hose duct. Failure to do so could result in severe injury.

(000288)

- Place ducting in desired configuration before operating unit. Tightly secure ducting end to outlet.
- Avoid sharp bends or 90° turns in ducting.
- Verify that ducting is not a high traffic area, and will not impede workers or other machinery. Care should be taken to prohibit the need to step or climb over ducting.
- DO NOT place ducting over combustible materials.
- DO NOT place ducting over surfaces that may damage it or reduce performance, such as water, sharp rocks or glass, electrical wiring, and piping.
- DO NOT place or drape anything over ducting such as covers, insulation, blankets or cloth, electrical wires, etc.

Heater Startup



DANGER

Electrocution. In the event of electrical accident, immediately shut power OFF. Use non-conductive implements to free victim from live conductor. Apply first aid and get medical help. Failure to do so will result in death or serious injury.

(000145)



DANGER

Electrocution. Do not use unit if electrical wiring is cut or worn through. Doing so will result in death or serious injury.

(000378)

⚠ DANGER

Electrocution. Verify electrical system is properly grounded before applying power. Failure to do so will result in death or serious injury. (000152)

⚠ WARNING

Hot Surfaces. When operating machine, do not touch hot surfaces. Keep machine away from combustibles during use. Hot surfaces could result in severe burns or fire. (000108)

⚠ WARNING

Equipment damage. Do not attempt to start or operate a unit in need of repair or scheduled maintenance. Doing so could result in serious injury, death, or equipment failure or damage. (000291)

⚠ CAUTION

Equipment or property damage. Do not block air intake or restrict proper air flow. Doing so could result in unsafe operation or damage to unit. (000229)

General Overview

Heater and fan behavior are driven by several user-defined benchmarks. The fan starts when the fan motor breaker and fan motor switch are ON.

Operational Procedure

1. Place ducting in desired configuration.
2. Make all necessary electrical connections to power the unit.
3. Perform walk around inspection; verify blower intake and burner chimney are clear.
4. Open fuel supply and return valves.
5. Turn main power disconnect switch to ON.
6. Turn fan switch ON.

IMPORTANT NOTE: Fan must be started before burner is started.

7. Turn burner switch ON. Wait for purge cycle to complete and watch for burner ignition.
8. Adjust high and low temperature settings on thermostats.
9. Close all access doors while unit is operating.

IMPORTANT NOTE: All doors on the unit must be closed when operating.

Adjusting Heater Output

Heater output is adjusted using the up and down arrows on the thermostat to set the desired temperature.

Thermostat

The thermostat is located inside the burner access door. Record the set temperature for future reference.

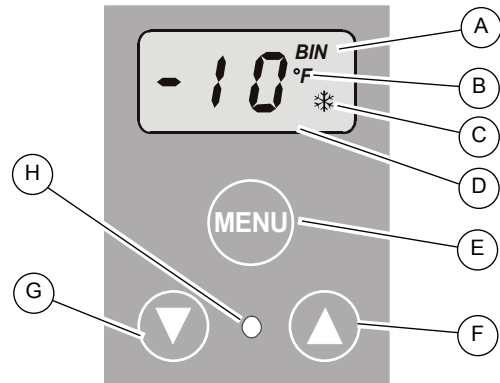

004794

Figure 3-1. Thermostat Features

A	Temperature offset indicator
B	Temperature units indicator
C	Operating mode indicator
D	Liquid Crystal Display (LCD)
E	MENU button
F	Up arrow button
G	Down arrow button
H	Output relay status indicator LED

Thermostat Control

Proceed as follows to access the advanced menu and edit operating parameters, such as temperature units.

1. Press the MENU button.
2. Press the up or down arrow buttons to reach desired function.
3. Press the MENU button to display the current value of the function.
4. Press the up or down arrow buttons until desired value is reached.
5. Press the MENU button to save the new value. The display will show the next parameter code.
6. Press and hold the up and down arrow buttons to return to the main screen.

NOTE: If the MENU button is not pressed after changing the function value, the new value will not be saved.

NOTE: If no buttons are pressed for 30 seconds while programming the thermostat, the display returns to the default temperature display. Any changes made are not saved.

See [Table 3-1](#) for thermostat functions.

Table 3-1. Thermostat Function Ranges and Settings

Function	Range	Factory Setting
On = Relay On Temperature	-40–212 °F (-40–100 °C)	High/Low Flame: 145 °F (63 °C) Threshold Thermostat: 100 °F (38 °C)
OFF = Relay Off Temperature	-40–212 °F (-40–100 °C)	High/Low Flame: 150 °F (66 °C) Threshold Thermostat: 180 °F (82 °C)
ASd = Anti-short Cycle Delay	0 to 12 minutes	0
SF = Sensor Failure Operation	0 = output de-energized 1 = output energized	0

NOTE: See thermostat manual for more information.

Heater Shutdown

1. Turn burner switch to OFF.
2. Allow five minutes of fan operation for cool down cycle, then turn fan motor switch to OFF.

NOTE: Turning the fan off before the burner has cooled could result in shorter burner unit life.

3. Turn fan switch to OFF.
4. Turn main power disconnect switch to OFF.
5. Close fuel supply and return valves.
6. Detach ducting and return to storage.
7. Close and secure access doors.

Emergency Shutdown

Remove power at the incoming power source for the unit in emergency situations.

This page intentionally left blank.

Section 4: Maintenance

Maintenance

Regular maintenance will improve performance and extend engine/equipment life. Generac Mobile Products, LLC. recommends that all maintenance work be performed by a Generac Mobile Products Authorized Service Dealer (GMP ASD). Regular maintenance, replacement, or repair of the emissions control devices and systems may be performed by any repair shop or person of the owner's choosing. To obtain emissions control warranty service free of charge, the work must be performed by a GMP ASD. See the emissions warranty.

Maintenance Tasks



WARNING

Vision loss. Eye protection is required when servicing unit. Failure to do so could result in vision loss or serious injury.

(000377)

Daily checks must be performed when the unit is operated continuously for extended periods of time. Daily checks and routine monthly checks can be performed by an authorized operator.

NOTE: Normal maintenance, service, and replacement of parts are the responsibility of the owner and are not considered defects in materials or workmanship within the terms of the warranty. It is strongly recommended that equipment be periodically checked by a GMP ASD.

Daily Walk Around Inspection

Inspect for conditions that could hinder performance or safety, such as (but not limited to) fuel leakage, blocked vents, loose or missing hardware, and improper electrical connections. Check for foreign matter blocking the vents and on top of the unit.

- Inspect outer cover for significant damage beyond scuffs and small nicks.
- Inspect for wire abrasion.
- Inspect electrical connectors and ground points for loose or missing hardware and improper electrical connections.
- Inspect all fuel hoses for deterioration.
- Verify hoses are not crushed, bent, or twisted.
- Verify there are no cracks or corrosion.

Maintenance Schedule

Periodic inspection, service, and maintenance of this unit is critical to ensuring reliable operation. The following is the manufacturer's recommended maintenance schedule. The maintenance items need to be performed more frequently if the unit is used in severe applications (such as very high or very low ambient conditions or extremely dirty or dusty environments). Use the unit hour meter or calendar time, whichever occurs first, from the previous maintenance interval to determine the next required maintenance interval.

NOTE: Some checks are based on hours of operation.

Follow all applicable safety alerts in this manual or the engine service manual before performing any maintenance checks or service.

This maintenance schedule reflects the minimum tasks needed to verify the unit remains operational. Some of the tasks can be performed by an authorized operator, and others must be performed by a GMP ASD.

NOTE: An authorized operator is one who has been trained by a GMP ASD in proper operation and inspection of this unit.

Maintenance Schedule

Daily	<ul style="list-style-type: none"> • Drain water from fuel filters. • Inspect burner assembly for damage or impurities. • Verify burner screws are properly tightened.
Every 3 Months	<ul style="list-style-type: none"> • Change in-line fuel burner filter. • Verify burner lockout feature is functioning. See burner manual.
Every 12 Months	<ul style="list-style-type: none"> • Complete a combustion check on burner. Contact a GMP ASD.
Every 500 Hours	<ul style="list-style-type: none"> • Remove and replace fuel filter elements. • Test thermostat opening temperature.
As Required	<ul style="list-style-type: none"> • Check fuses. • Inspect electrical wiring and connections. • Test burner pump delivery pressure. • Test burner lockout feature functionality. • Replace burner nozzles; do not clean. Verify combustion after change, between 2-3 years. • Purge fuel system. • Clean photocell glass cover. • Clean flame inspection window. • Inspect line, pump, and nozzle filter boxes. Clean or replace as necessary. • Remove water or impurities from the bottom of the fuel tank using a separate pump every five years.
NOTE: For more information, see the burner manual.	

Other Maintenance Checks

The following inspections should be performed by an authorized service technician, or a properly trained authorized operator. These maintenance items require a high level of experience and skill to evaluate and correct.

- Inspect hoses and connections.
- Inspect fuel supply system.

Section 5: Troubleshooting

General Troubleshooting Guide

Problem	Cause	Solution
Excessive fuel consumption	Leaks in fuel supply system.	Locate source of leak and repair as required.
	Poor fuel quality; improper type of fuel.	Drain fuel and replace with proper grade and quality of fuel for operating condition.
	Electronic control system problem or basic burner problem.	Contact a GMP ASD.
Low-pressure fuel system — fuel pressure low	Restricted fuel filter.	Replace fuel filter.
	Restricted fuel line.	Locate restriction, repair as required.
	Faulty transfer pump.	Contact a GMP ASD.
Burner emits black, gray, or blue smoke	Unused fuel.	Adjust the screws at top of the cam to adjust the air damper. See burner manual for more information.
	Insufficient oxygen.	
Burner overheats	Faulty or wrong type of thermostats.	Test thermostat opening temperature, replace thermostats as required.
	Incorrect grade of fuel.	Drain fuel and replace with proper grade and quality of fuel for operating condition.
Burner doesn't light	Faulty thermostat(s) (does not close; no call for heat).	Test thermostat(s); replace thermostat(s) as required.
Entire electrical system does not function	Blown fuse.	Replace fuse.
NOTE: See the burner manual for more information about burner fault symbols.		

This page intentionally left blank.

Section 6: Installation Diagrams

Blower Panel (1 of 2)

380 VOLT 4.2MBTU BLOWER PANEL

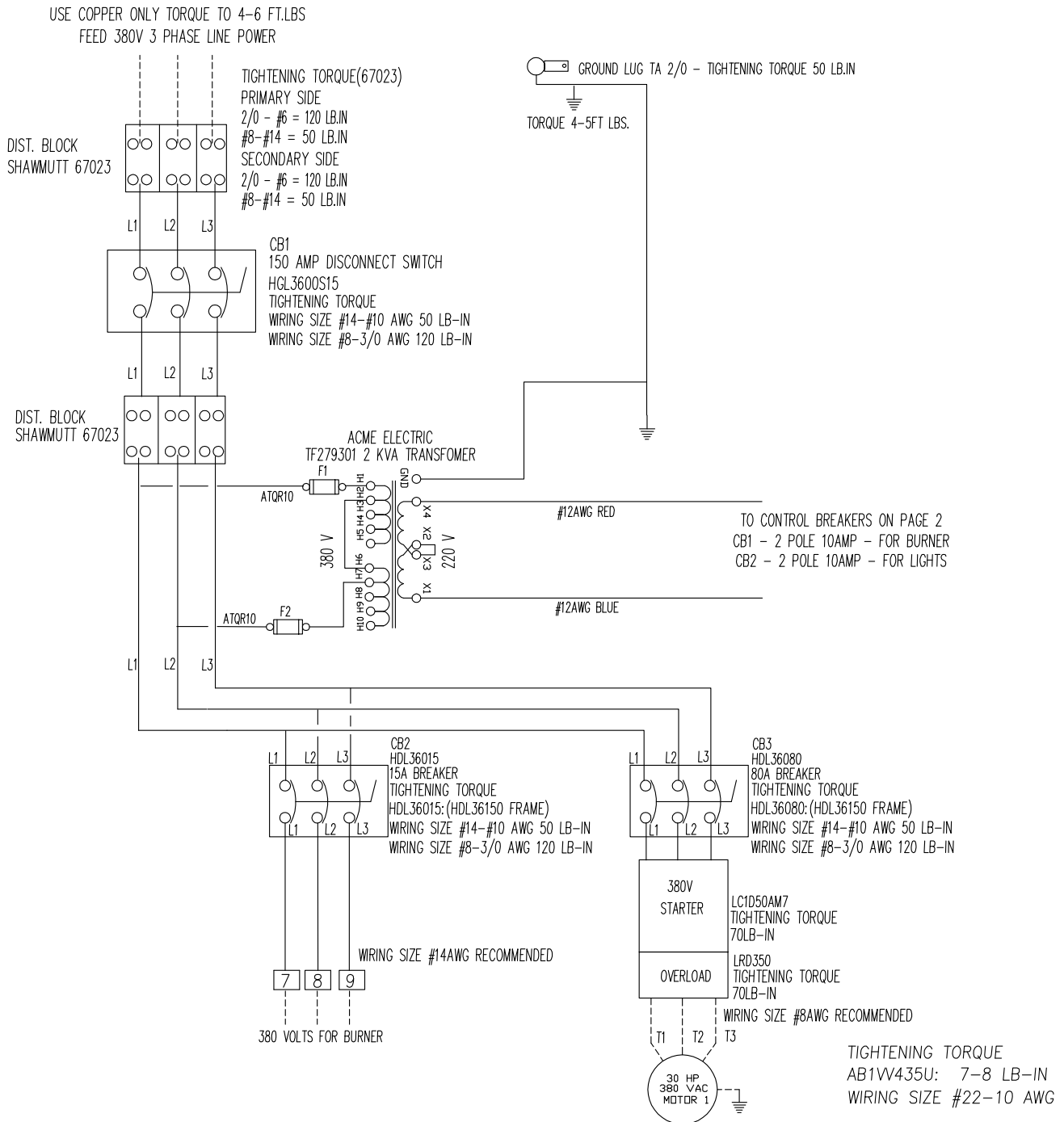

Blower Panel (2 of 2)

380 VOLT 4.2MBTU BLOWER PANEL

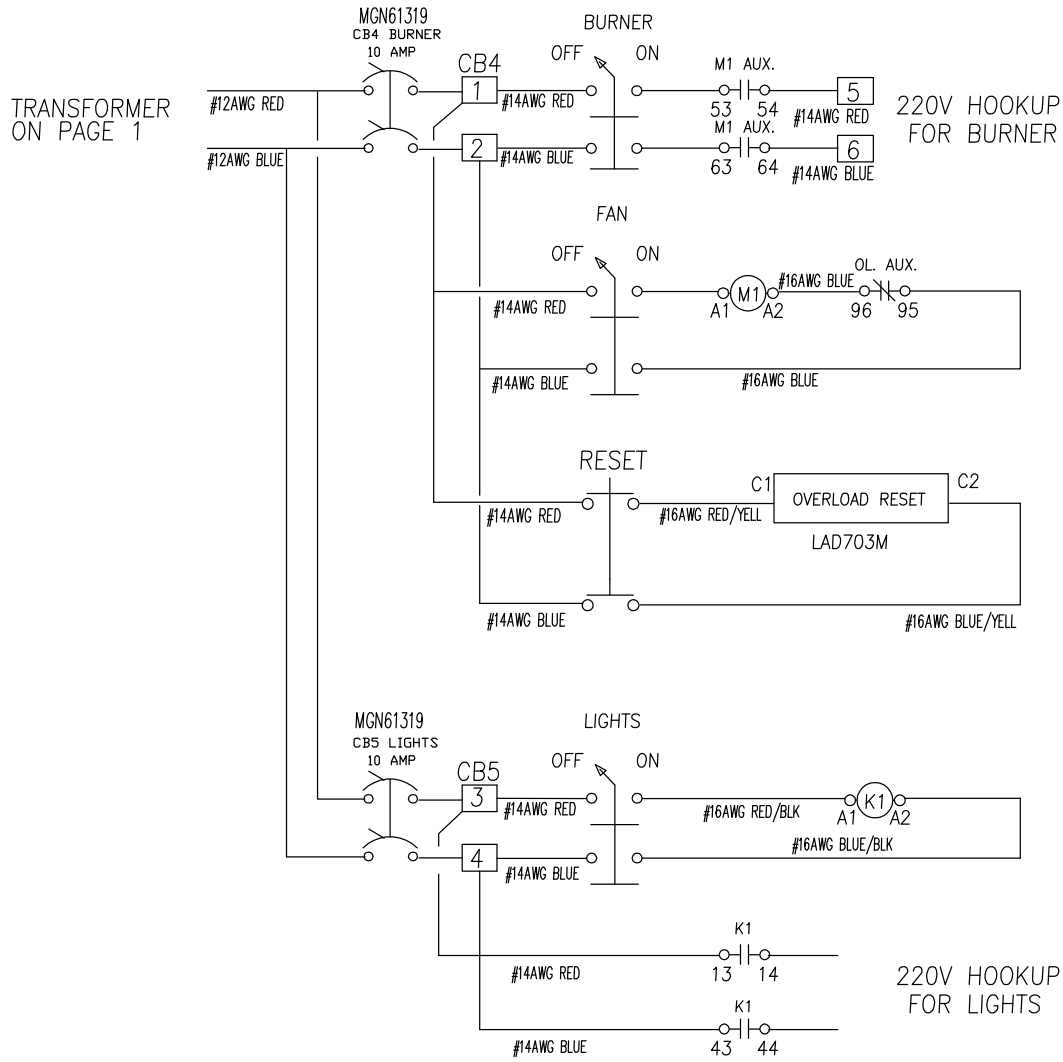

TIGHTENING TORQUE
 AB1V435U: 7-8 LB-IN
 WIRING SIZE #22-10 AWG

Wiring Diagram

WIRING — DIAGRAM

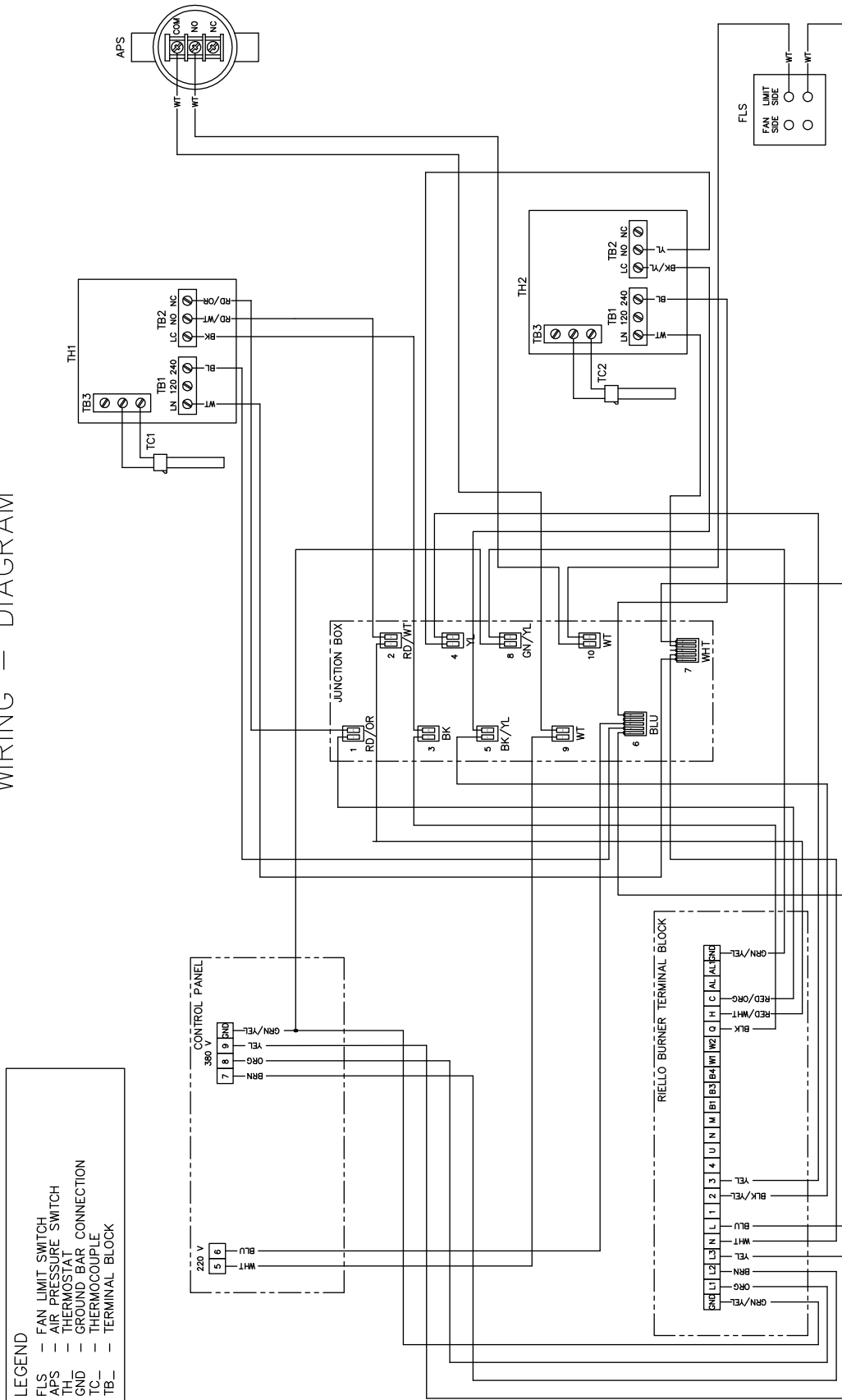

- LEGEND**
- FAN LIMIT SWITCH
 - AIR PRESSURE SWITCH
 - THERMOSTAT
 - GROUND BAR CONNECTION
 - THERMOCOUPLE
 - TERMINAL BLOCK

This page intentionally left blank.

This page intentionally left blank.

This page intentionally left blank.

Part No. 10000012115 Rev. A 05/05/17

©2017 Generac Mobile Products

All rights reserved.

Specifications are subject to change without notice.

No reproduction allowed in any form without prior written consent from Generac Mobile Products.

GENERAC[®]

MAC

Generac Mobile Products

215 Power Drive, Berlin, WI 54923

GeneracMobileProducts.com | 800-926-9768 | 920-361-4442